



DATASHEET

Issue 2.0



Multifunction Meters

Transducers & Isolators

Temperature Controllers

Converters & Recorders

Digital Panel Meters

Current Transformers

Analogue Panel Meters

Shunts

Digital Multimeters

Clamp Meters

Insulation Testers

BETA 10P, 20P, 30P 40P DIGITAL PANEL METERS

The digital panel meter Beta P Series have been designed for industrial applications, which frequently require precise and on site adjustment of the display range.

Features

- Fast & Easy Installation on panel without any need of external swivel screws
- 4 Digits ultra bright LED Display (up to 9999)
- On site Programmable CT/PT Ratios
- User selectable CT Secondary 1A/5A
- User selectable PT Secondary from 100 VLL to 500 VLL
- User selectable 3ph-3wire / 3ph-4wire / single phase Network
- Wide auxillary Power Supply which can accept any input between
- 40V- 300V AC/DC

SUBJECT TO CHANGE WITHOUT NOTICE

This manual superseded all previous versions – please keep for future reference



Application

The digital panel meter Beta P Series have been designed for industrial applications, which frequently require precise and on site adjustment of the display range. It can be used in industrial automation and for laboratory uses.

Product Features

| | |
|--|---|
| True RMS measurement | The instrument measures distorted waveform up to 15th Harmonic. |
| On site programmable PT/CT ratios | It is possible to program primary of external potential Transformer (PT) for Voltage DPM & primary of external Current Transformer (CT) for Current DPM on site via front panel keys by entering into Programming mode. |
| User selectable CT Secondary 5A/1A | The secondary of external Current Transformer (CT) can be programmed on site to either 5A or 1A for Current DPM using front panel keys. |
| User selectable PT Secondary | The secondary of external Potential Transformer (PT) can be programmed on site from 100 VLL to 500 VLL for Voltage DPM using front panel keys. |
| Higher Security | Provides Security with user programmable password protection. |
| User selectable CT Primary | The Primary of current transformer can be programmed on site from 1A to 999kA for Current DPM using front panel keys. |
| User selectable PT Primary | The Primary of Potential transformer can be programmed on site from 60 VLN to 999 kVLN for single Phase Voltage DPM & 100VLL to 999 kVLL for three Phase Voltage DPM using front panel keys. |
| User selectable 3 phase 3Wire or 4Wire or Single phase Network | User can program on site the network connection as either 3 Phase 3 Wire or 4 Wire or single phase network using front panel keys. |
| Onsite selection of Auto scroll / Fixed Screen | User can set the display in auto scrolling mode or fixed screen mode using front panel keys. |
| Function keys | Using two function keys it is possible to Display various parameters in Current and Voltage DPM. These function keys are also used for programming Password, Network selection, CT/PT Primary & Secondary values, Reset min/max values, Auto ON/OFF mode selection. |

| | |
|---|---|
| Screen No. storage | In case of power failure, the instrument memorizes the last screen stored. For every 1 min. the instrument stores the screen no. in the non-volatile memory. |
| Min Max storage of parameters possible | The instrument stores minimum and maximum values for System Voltage (in case of Beta 20P / Beta 40P) and System Current (in case of Beta 10P / Beta 30P). Every 60 sec stored values are updated. |
| Low back depth | The instrument has very low back depth (behind the panel) of less than 54mm for 96x96 and 68mm for 48x96 type DPM. |
| Available in two different Sizes | DPM is available in two different sizes 96x96 and 48x96. |
| Enclosure Protection for dust and water | Conforms to IP 50 (for front face) & IP 20 (for back) as per IEC60529. |
| EMC Compatibility | Compliance to International standard IEC 61326. |
| Interference Emission | IEC 61326-1 2005, Class A |
| Interference Immunity | IEC 61326-1 2005 |
| Electrostatic disc (ESD) arge | IEC 61000-4-2 -- 4kV/8kV contact/air. |
| EM Field | IEC 61000-4-3 -- 10 V/m (80 MHz to 1 GHz) -- 3 V/m (1.4 GHz to 2 GHz) -- 1 V/m (2 GHz to 2.7 GHz) |
| Burst | IEC 61000-4-4 -- 2 kV (5/50 ns, 5 kHz) |
| Surge | IEC 61000-4-5 -- 1 kVLL / 2 kVLN. |
| Conducted RF | IEC 61000-4-5 -- 3 V (150 kHz to 80 MHz) |
| Rated Power Frequency magnetic Field | IEC 61000-4-8 -- 30 A/m |
| Voltage dip | IEC 61000-4-11 -- 0% during 1 cycle. -- 40% during 10/12 cycles. -- 70% during 25/30 cycles. |
| Short interruptions | IEC 61000-4-11 -- 0% during 25/30 cycles. 25 cycles for 50 Hz test 30 cycles for 60 Hz test. |

Technical Specifications

| Accuracy | |
|-----------------|--|
| Voltage | ±0.5% of range + 1 Digit (10... 100% of Nominal value) |
| Current | ±0.5% of range + 1 Digit (10... 100% of Nominal value) |

| Reference conditions for Accuracy | |
|--|--------------------------------------|
| Reference temperature | 23°C +/- 2°C |
| Input waveform | Sinusoidal (distortion factor 0.005) |
| Input frequency | 50 or 60 Hz ±2% |
| Auxiliary supply voltage | Rated Value ±1% |
| Auxiliary supply frequency | Rated Value ±1% |

| Input Voltage (Beta20P / Beta40P) | |
|--|--|
| Nominal input voltage (AC RMS) | Phase -Neutral 290VL-N Line-Line 500V L-L |
| Max continuous input voltage | 120% of rated value |
| Nominal input voltage burden | < 0.3 VA approx.per phase. |
| System PT secondary values | For Single Phase DPM- 60VLN to 290VLN programmable on site & for Three Phase DPM- 100VLL to 500VLL programmable on site. |
| System PT primary values | For Single Phase DPM- 60VLN to 999kVLN programmable on site & for Three Phase DPM- 100VLL to 900kVLL programmable on site. |

| Input Current (Beta10P / Beta30P) | |
|--|--------------------------------------|
| Nominal input current | 5A AC RMS |
| System CT secondary values | 1A & 5A programmable on site |
| System CT primary values | From 1A up to 999kA (for 1 or 5 Amp) |
| Max continuous input current | 120% of rated value |
| Nominal input current burden | < 0.2 VA approx. per phase |

| Auxiliary Supply | |
|-------------------------|--------------------------|
| External Aux | 40 V - 300V AC/DC (± 5%) |
| Frequency range | 45 to 65 Hz |
| VA burden | 3 VA Approx. |

| Overload Withstand | |
|---------------------------|--|
| Voltage | 2 x rated value for 1 second, repeated 10 times at 10 second intervals |
| Current | 20x rated value for 1 second, repeated 5 times at 5 min intervals. |

| Influence of Variations | |
|--------------------------------|---|
| Temperature coefficient | 0.025% /°C for Voltage 0.05% /°C for Current |

| Operating Measuring Ranges | |
|-----------------------------------|----------------------------|
| Voltage Range | 10... 120% of rated value |
| Current Range | 10 ... 120% of rated value |
| Frequency | 45...65 Hz |

| Display update rate | |
|-----------------------------|---------------|
| Response time to step input | 1 sec approx. |

| Enclosure | |
|------------------|-------|
| Front | IP 50 |
| Back | IP 20 |

| Safety | |
|-----------------------|--|
| Pollution degree | 2 |
| Installation category | III |
| High voltage taste | 3.3 kV AC, 50Hz for 1 minute between Aux. and measuring inputs |

| Environmental | |
|-----------------------|-------------------------------|
| Operating temperature | 0°C to + 50°C |
| Storage temperature | -25°C to +70°C |
| Relative humidity | 0... 95% non condensing |
| Warm up time | Minimum 3 minute |
| Shock | 15g in 3 planes |
| Vibration | 10... 55 Hz, 0.15mm amplitude |

| Dimensions and Weights | |
|-------------------------------|------------------------------|
| a) 96x96 DPM | |
| Bezel size | 96 mm x 96 mm DI N 43 718. |
| Panel cut-out | 92+0.8mm x 92 + 0.8mm. |
| Overall depth | 55 mm. |
| Weight | 310 gm. Approx. |
| b) 48x96 DPM | |
| Bezel size | 96 mm x 48 mm DI N 43 718 |
| Panel cut-out | 92 + 0.8 mm x 43.5 + 0.6 mm. |
| Overall depth | 68 mm. |
| Weight | 250 gm. Approx. |

| Applicable Standards | |
|-----------------------------|---|
| EMC | IEC 61326-1: 2005 |
| Safety | IEC 61010-1-2001, Permanently connected use |
| IP for water & dust | IEC60529 |

Parameters measured and displayed

| A) Beta 40P AC Voltmeter | |
|--------------------------|--|
| Network type | Displayed Parameter |
| 1) 3 Phase 4 wire | a. Phase –Neutral Voltage R / L1 b. Phase –Neutral Voltage Y / L2 c. Phase –Neutral Voltage B / L3 d. Line-Line Voltage RY / L1-L2 e. Line-Line Voltage YB / L2-L3 f. Line-Line Voltage BR / L3-L1 g. System Voltage V h. Max. system voltage V i. Min. system voltage V |
| 2) 3 Phase 3 wire | a. Line-Line Voltage RY / L1-L2 b. Line-Line Voltage YB / L2-L3 c. Line-Line Voltage BR / L3-L1 d. System Voltage V e. Max. system voltage V f. Min. system voltage V |
| 3) 1 Phase 2 wire | a. Phase –Neutral Voltage V b. Max voltage V c. Min voltage V |

| B) Beta 30P AC Ammeter | |
|--|--|
| Network type | Displayed Parameter |
| 1) 3 Phase 4 wire and 3 Phase 3 Wire | a. Phase Current AR b. Phase Current AY c. Phase Current AB d. System Current A e. Max. system Current A f. Min. system Current A |
| 2) 1 Phase 2 wire | a. Phase Current A e. Max. Phase Current A f. Min. Phase Current A |

| C) Beta 20P AC Voltmeter | |
|--------------------------|--|
| Network type | Displayed Parameter |
| 3) 1 Phase 2 wire | a. Phase Voltage V b. Max voltage V c. Min voltage V |

| D) Beta 10P AC Ammeter | |
|------------------------|--|
| Network type | Displayed Parameter |
| 2) 1 Phase 2 wire | a. Phase Current A e. Max. Phase Current A f. Min. Phase Current A |

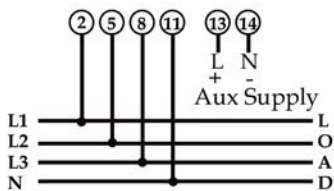
Connection
A) For 96x96 DPM BETA 40P

3PH - 4 Wire Network

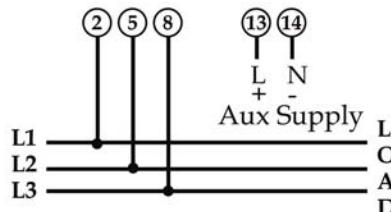

3PH - 3 Wire Network

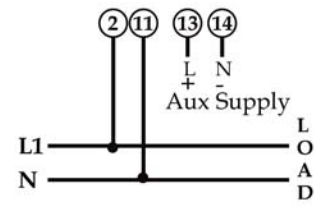

1PH Network

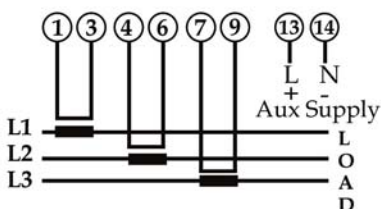
For 96x96 DPM BETA 30P

3PH - 4 Wire Network

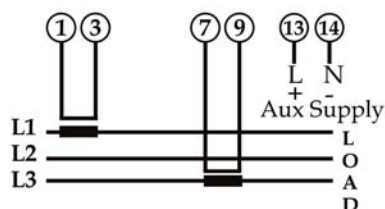

3PH - 3 Wire Network

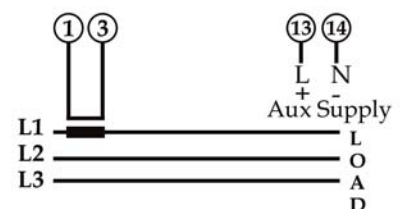

1PH Network

Connection

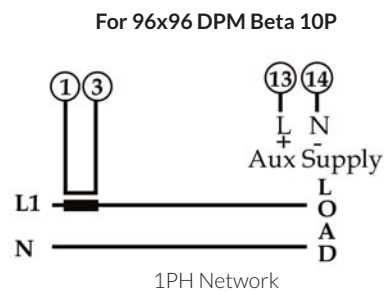
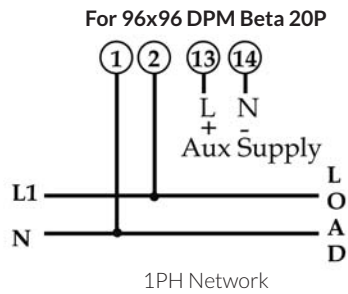

*Note: For Measurement of parameters in Beta 40P DPM Voltage must be present between terminal 2 & 11 for single phase or 3 phase 4 wire network and between terminal 2 & 5 or 2 & 8 for 3 phase 3 wire network. And for Beta 30 PDPM current must be present between terminal 1 & 3 for 3 phase 4 wire or 3 phase 3 wire or single phase network.

B) For 48x96 DPM Beta 40 P

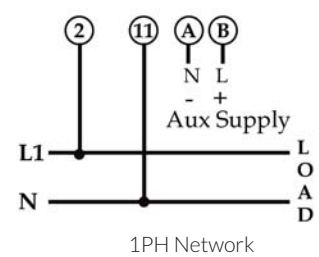
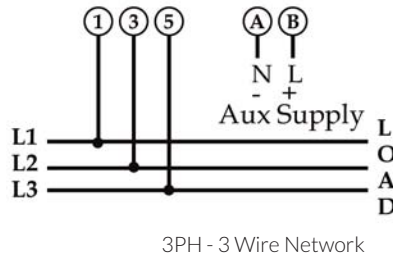
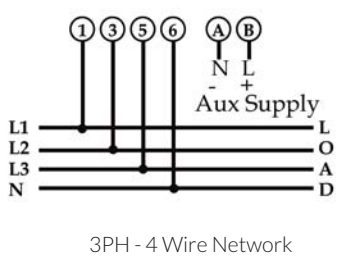

For 48x96 DPM Beta 30 P

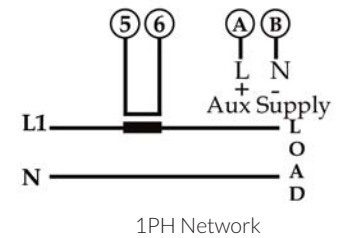
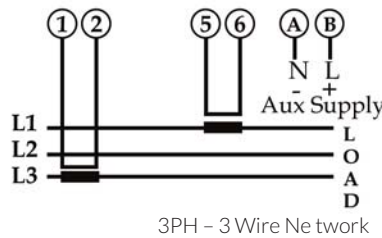
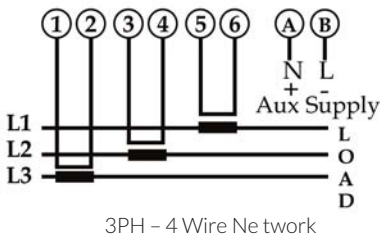

For 48x96 DPM Beta 20P

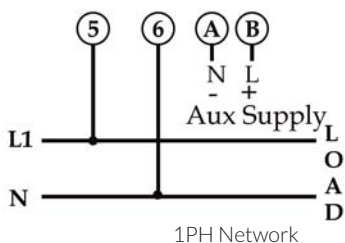

For 96x96 DPM Beta 10P

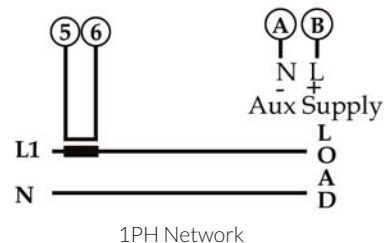

*Note: For Measurement of parameters in Beta 40P LD DPM Voltage must be present between terminal 1 & 6 for single phase or 3 phase 4 wire network and between terminal 1 & 3 or 1 & 5 for 3 phase 3 wire network. And for Beta 30P LD DPM current must be present between terminal 5 & 6 for 3 phase 4 wire or 3 phase 3 wire or single phase network.

Installation

Easy Clip in Installation on Panel for 96 x 96 size

Easy Clip-in mounting for 96x96 size

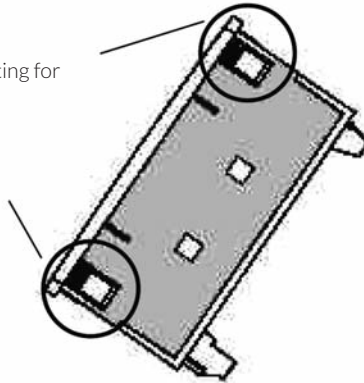

No need of swivel screws

A) For 96x96 DPM

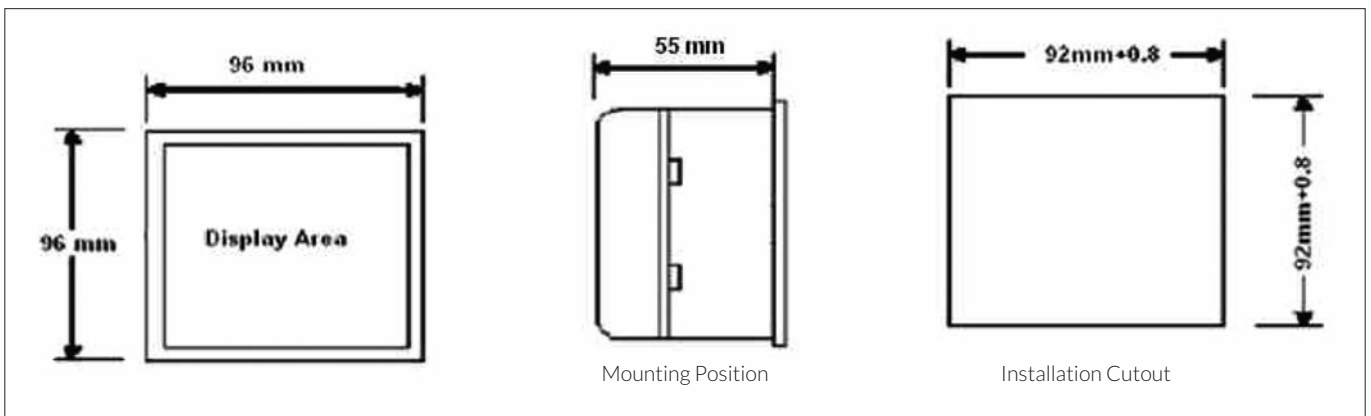

B) For 48x96 DPM

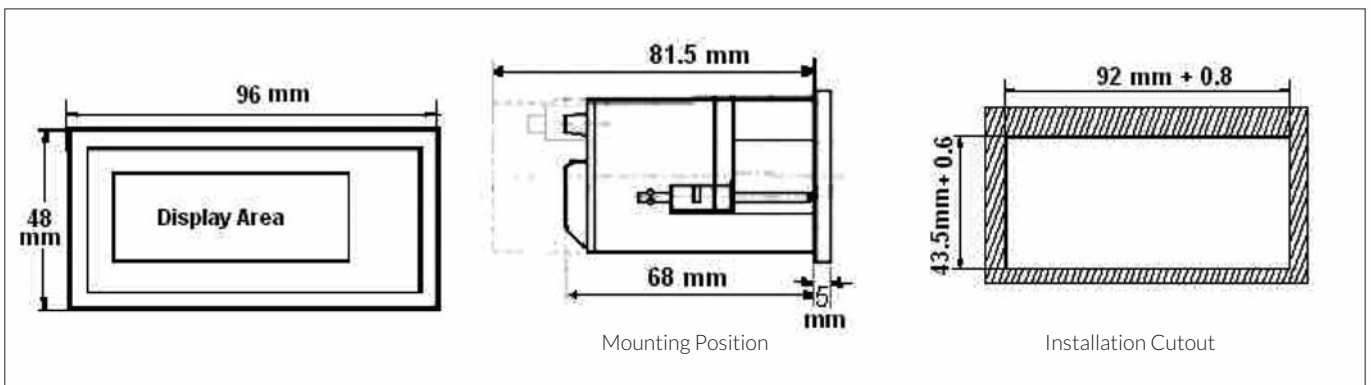

Ordering Information

| | | | | | | | | | |
|---------------|--------------------|---|---|---|---|----|---|---|-------|
| Product Code | BT14- | X | X | X | X | XX | X | X | 00000 |
| Size | 48X96 | E | | | | | | | |
| | 96X96 | G | | | | | | | |
| System Type | 1P | | 1 | | | | | | |
| | 3P | | 3 | | | | | | |
| Input Type | AC Voltmeter ACV | | | V | | | | | |
| | AC Ammeter ACI | | | K | | | | | |
| Display Size | 14mm | | | | 1 | | | | |
| | 20mm | | | | 2 | | | | |
| Input Range | 5/1A | | | | | 81 | | | |
| | 60-290LN | | | | | 4A | | | |
| | 60-600LN | | | | | 4B | | | |
| | 120-600LN | | | | | 4C | | | |
| | 100-500LL | | | | | 4D | | | |
| Power Supply | 40-300U | | | | | | L | | |
| IP Protection | W/O IP Protection | | | | | | | 0 | |
| | With IP Protection | | | | | | | 1 | |

Contact

Sifam Tinsley Instrumentation Ltd

1 Warner Drive
 Springwood Industrial Estate
 Braintree, Essex
 CM7 2YW

Tel: 01376 335271
 E-mail: sales@sifamtinsley.com

www.sifamtinsley.co.uk