

Multifunction Meters

Transducers & Isolators

Temperature Controllers

Converters & Recorders

Digital Panel Meters

Current Transformers

Analogue Panel Meters

Shunts

Digital Multimeters

Clamp Meters

Insulation Testers

B2, B3, B4, B5, B6 MEASURING SHUNTS

Features

- Extension of d.c. current measuring ranges of moving-coil ammeters
- Accuracy class 0.5
- Shunts of 1...25 A ranges (and on request, B2 40...150 A) are fixed on an isolating base
- The isolating base is adapted to be assembled on a 35 mm DIN rail
- On request, additional chemical coating are available: laccering, silver or nickel plating

SUBJECT TO CHANGE WITHOUT NOTICE

This manual superseded all previous versions – please keep for future reference

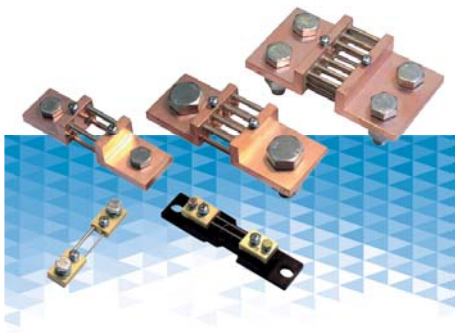

Features

1A
...
18 kA

Class
0.5

DIN
35 mm

Inputs

I

DC

Outputs

50 mV

60 mV

75 mV

100 mV

150 mV

Example of application

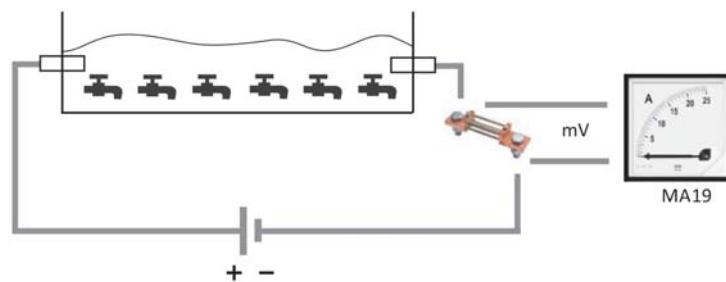

Process of fillings electroplating.

Kind of version

Version A (on an isolating base)

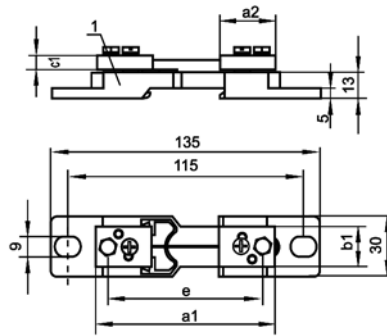

Version D

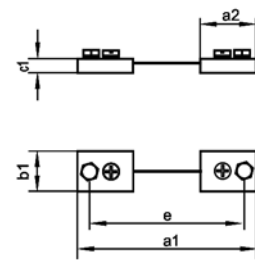

Version B

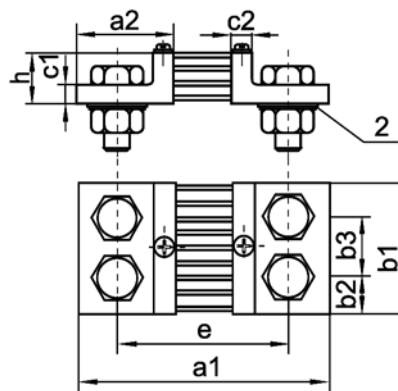

Version C

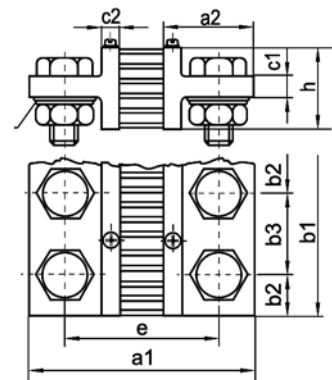

Fig.1. Fixing dimensions of shunts
1 - isolating base, 2 - round spring washer.

2 60 mV												Current terminals			
IN [A]	Version	a1	a2	b1	b2	b3	c1	c2	e	h	Weight [kg]	LZ	Bolt	P	N
1; 1.5; 2.5; 4; 6; 10; 15; 25	A	90	28	20	-	-	8	-	78	-	0.13	2 x 1	M5 x 12	5.5	-
40, 60, 100, 150	A, D	100	33	20	-	-	8	-	80	-	0.13	2 x 1	M8 x 16	8.5	-
250	B	145	55	30	15	-	10	10	105	30	0.60	2 x 1	M12 x 40	13	M12
400	B	145	55	40	20	-	10	10	105	30	0.85	2 x 1	M16 x 45	17	M16
600	B	145	55	40	20	-	10	10	105	30	0.85	2 x 1	M16 x 45	17	M16
1000	B	165	65	60	30	-	10	10	115	30	1.45	2 x 1	M20 x 50	21	M20
1500	B	165	65	90	21	48	10	10	115	30	2.00	2 x 2	M16 x 45	17	M16
2500	B	165	65	120	30	60	10	10	115	30	2.90	2 x 2	M20 x 50	21	M20
4000	C	165	65	120	30	60	15	10	115	60	4.30	2 x 2	M20 x 60	21	M20
6000	C	175	70	154	25	52	25	15	125	130	10.50	2 x 3	M20 x 75	21	M20
10000	C	185	75	206	25	52	30	20	135	170	21.00	2 x 4	M20 x 80	21	M20
15000	C	185	75	310	25	52	30	20	135	170	32.00	2 x 6	M20 x 80	21	M20



B2

3 150 mV												Current terminals			
IN [A]	Version	a1	a2	b1	b2	b3	c1	c2	e	h	Weight [kg]	LZ	Bolt	P	N
1; 1.5; 2.5; 4; 6; 10; 15; 25	A	90	28	20	-	-	8	-	78	-	0.14	2 x 1	M5 x 12	5.5	-
40, 60, 100, 150	D	225	33	25	-	-	8	-	205	-	0.23	2 x 1	M8 x 16	8.5	-
250	B	270	55	30	15	-	10	10	230	50	0.68	2 x 1	M12 x 40	13 M	12
400	B	270	55	40	20	-	10	10	230	50	1.05	2 x 1	M16 x 45	17 M	16
600	B	270	55	40	20	-	10	10	230	50	1.16	2 x 1	M16 x 45	17 M	16
1000	B	290	65	70	35	-	10	10	240	60	2.15	2 x 1	M20 x 50	21 M	20
1500	C	290	65	90	21	48	15	10	240	60	3.10	2 x 2	M16 x 60	17 M	16
2500	C	290	65	120	30	60	15	10	240	60	5.20	2 x 2	M20 x 60	21 M	20
4000	C	300	70	120	30	60	25	15	250	130	8.30	2 x 2	M20 x 75	21 M	20
6000	C	300	70	154	25	52	25	15	250	130	15.00	2 x 3	M20 x 75	21 M	20
10000	C	310	75	206	25	52	30	20	260	170	28.00	2 x 4	M20 x 80	21 M	20
15000	C	310	75	310	25	52	30	20	260	170	35.00	2 x 6	M20 x 80	21 M	20



B3

4 50 mV												Current terminals			
IN [A]	Version	a1	a2	b1	b2	b3	c1	c2	e	h	Masa [kg]	LZ	Bolt	P	N
1; 1.5; 2.5; 4; 6; 10; 15; 25	A	90	28	20	-	-	8	-	78	-	0.13	2 x 1	M5 x 12	5.5	-
40, 60, 100, 150	D	100	33	20	-	-	8	-	80	-	0.13	2 x 1	M8 x 16	8.5	-
250	B	138	55	30	15	-	10	10	98	30	0.60	2 x 1	M12 x 40	13	M12
400	B	138	55	40	20	-	10	10	98	30	0.85	2 x 1	M16 x 45	17	M16
600	B	138	55	40	20	-	10	10	98	30	0.85	2 x 1	M16 x 45	17	M16
1000	B	158	65	60	30	-	10	10	108	30	1.45	2 x 1	M20 x 50	21	M20
1500	B	158	65	90	21	48	10	10	108	30	2.00	2 x 2	M16 x 45	17	M16
2500	B	158	65	120	30	60	10	10	108	30	2.90	2 x 2	M20 x 50	21	M20
4000	C	158	65	120	30	60	15	10	108	60	4.30	2 x 2	M20 x 60	21	M20
6000	C	168	70	154	25	52	25	15	118	130	10.50	2 x 3	M20 x 75	21	M20
10000	C	178	75	206	25	52	30	20	128	170	21.00	2 x 4	M20 x 80	21	M20
15000	C	178	75	310	25	52	30	20	128	170	32.00	2 x 6	M20 x 80	21	M20



B4

5 75 mV												Current terminals			
IN [A]	Version	a1	a2	b1	b2	b3	c1	c2	e	h	Weight [kg]	LZ	Bolt	P	N
1; 1.5; 2.5; 4; 6; 10; 15; 25	A	90	28	20	-	-	8	-	78	-	0.14	2 x 1	M5 x 12	5.5	-
40, 60, 100, 150	D	115	33	25	-	-	8	-	95	-	0.17	2 x 1	M8 x 16	8.5	-
250	B	160	55	30	15	-	10	10	120	30	0.63	2 x 1	M12 x 40	13	M12
400	B	160	55	40	20	-	10	10	120	30	0.92	2 x 1	M16 x 45	17	M16
600	B	160	55	40	20	-	10	10	120	30	1.00	2 x 1	M16 x 45	17	M16
1000	B	180	65	60	30	-	10	10	130	30	1.75	2 x 1	M20 x 50	21	M20
1500	B	180	65	120	30	60	10	10	130	30	2.30	2 x 2	M16 x 45	17	M16
2500	C	180	65	120	30	60	15	10	130	60	3.10	2 x 2	M20 x 60	21	M20
4000	C	190	70	120	30	60	25	15	140	130	5.20	2 x 2	M20 x 75	21	M20
6000	C	190	70	154	25	52	25	15	140	130	11.20	2 x 3	M20 x 75	21	M20
10000	C	200	75	206	25	52	30	20	150	170	22.00	2 x 4	M20 x 80	21	M20
15000	C	200	75	310	25	52	30	20	150	170	33.00	2 x 6	M20 x 80	21	M20



B5

6 100 mV												Current terminals			
IN [A]	Version	a1	a2	b1	b2	b3	c1	c2	e	h	Weight [kg]	LZ	Bolt	P	N
1; 1.5; 2.5; 4; 6; 10; 15; 25	A	90	28	20	-	-	8	-	78	-	0.14	2 x 1	M5 x 12	5.5	-
40, 60, 100, 150	D	145	33	25	-	-	8	-	125	-	0.20	2 x 1	M8 x 16	8.5	-
250	B	190	55	30	15	-	10	10	150	30	0.65	2 x 1	M12 x 40	13	M12
400	B	190	55	40	20	-	10	10	150	30	1.00	2 x 1	M16 x 45	17	M16
600	B	190	55	40	20	-	10	10	150	30	1.11	2 x 1	M16 x 45	17	M16
1000	B	210	65	60	30	-	10	10	160	30	2.00	2 x 1	M20 x 50	21	M20
1500	B	210	65	120	30	60	10	10	160	30	2.50	2 x 2	M16 x 45	17	M16
2500	C	210	65	120	30	60	15	10	160	60	3.20	2 x 2	M20 x 60	21	M20
4000	C	220	70	120	30	60	25	15	170	130	5.80	2 x 2	M20 x 75	21	M20
6000	C	220	70	154	25	52	25	15	170	130	12.00	2 x 3	M20 x 75	21	M20
10000	C	230	75	206	25	52	30	20	180	170	23.00	2 x 4	M20 x 80	21	M20
15000	C	230	75	310	25	52	30	20	180	170	34.00	2 x 6	M20 x 80	210	M20



B6

IN - rated current

LZ - number of terminals

Bolt - hexagon bolt

P - washer

N - nut

Voltage terminals - two M5 x 8 cylinder-head bolts with a cruciform cavity + 5.5 washers + 5.1 spring washers

Technical data

Electromagnetic compatibility	noise immunity	acc. to EN 61000-6-2
	noise emissions	acc. to EN 61000-6-4
Accuracy class	0.5	
Shunt calibration	B2, B4, B5, B6 of 1 .. 10 A ranges	considering the 10 mA current of the meter measuring element
	B3 of 1 .. 10 A ranges	considering the 10 mA current of the meter measuring element
Shunts dimensions	acc. to DIN 43 703 standard	
Testing voltage of shunts with an isolating base	5 kV	
Resistance for connection wires from shunt to the meter	35mΩ for the operation with all the Shunts of 150A or below and all the Shunts above 150A 75Ω is recommended	

Ordering

Product Code	YN01-	XX	XX	X	X	S	00000
Primary Current	1A	01					
	2A	02					
	5A	03					
	10A	04					
	15A	05					
	20A	06					
	25A	07					
	30A	08					
	32A	09					
	40A	10					
	50A	11					
	60A	12					
	63A	13					
	70A	14					
	75A	15					
	80A	16					
	100A	17					
	125A	18					
	150A	19					
	160A	20					
	200A	21					
	250A	22					
	300A	23					
	400A	24					
	500A	25					
	600A	26					
	750A	27					
	800A	28					
	1000A	29					
	1200A	30					
	1250A	31					
	1500A	32					
	1600A	33					
	2000A	34					
	2500A	35					
	3000A	36					
	4000A	37					
	5000A	38					
	6000A	39					
	7500A	40					
	630A	41					
	192A	42					
	175A	43					
	1800A	44					
	3A	45					
	1400A	46					
	350A	47					
	120A	48					
	10000A	49					
Voltage Drop	50mV		50				
	60mV		60				
	75mV		75				
	100mV		10				
	150mV		15				
	0.50%			5			
	1%			1			
	Insulating base				B		
without insulating base				W			

Contact



Sifam Tinsley Instrumentation Ltd

1 Warner Drive
Springwood Industrial Estate
Braintree, Essex
CM7 2YW

Tel: 01376 335271
E-mail: sales@sifamtinsley.com

www.sifamtinsley.co.uk