



DATASHEET

Issue 1.0



Multifunction Meters

Transducers & Isolators

Temperature Controllers

Converters & Recorders

Digital Panel Meters

Current Transformers

Analogue Panel Meters

Shunts

Digital Multimeters

Clamp Meters

Insulation Testers

SIGMA SERIES LML METER

ANALOGUE PANEL METER

SUBJECT TO CHANGE WITHOUT NOTICE

This manual superseded all previous versions – please keep for future reference



Application

The Watt and Var meters, LML 96 are offered for the following AC systems

- Single phase
- 3 phase balanced load 3 or 4 wire
- 3 phase unbalanced load 3 or 4 wire

These instruments are suitable to indicate forward (export / out going) and reverse (import / in coming) power flow.

They can be used both on sinusoidal and non - sinusoidal current. These meters offer several advantages in Switchboard and Generating Set panels. Number of meters can be mounted in a Panel Cut out (Mosaic Mounting).The Bezel, Front window glass and Dial can be easily replaced.

Applicable Standards

Nominal case and cutout dimensions for indicating Electrical instruments	DIN IEC 61554
Scale and pointer for electrical measuring instruments	DIN 43802
Connections and Terminal markings for panel meters	DIN 43807
Terminal bolts/leads	DIN 46200/46282
Clamp straps or connections	DIN 4622
Safety requirements and protective measures for Electrical indicating instruments and their accessories	DIN 40050, VDE 0110, VDE 0410 IEC 529, IEC 1010
Performance specifications for direct acting indicating analogue electrical	IEC51/DINEN60051 DIN 43701
Measuring instruments and their accessories Environmental conditions	VDE / VDI 3540
Front frames for indicating measuring instruments Principle dimensions	DIN 43718
ULCombustibility Class	UL 94 V-0
Mechanical strength (Free all test, Vibration test)	VDE 0411,IEC 1010

Comply with following European directives :

2004 / 108 / EC (EMC directive) , 2006 / 95 /EC (low voltage directive) & amendment 93/68/EEC, For CE Marking.

Scale and Pointer

Pointer	Knife - edge pointer	
Pointer deflection	0 ... 240°	
Scale characteristics	Linear	
Scale division	Coarse-fine	
Scale length	LML96	LML144
	142mm	230mm

Mechanical Data

Case details	Moulded square case suitable for mounting in Control / Switchgear panels, Machinery consoles
Case material	Polycarbonate, flame retardant and drip proof as per UL 94 V-0
Front facia	Glass
Colour of bezel	Black
Position of use	Vertical
Panel fixing	Mounting Clamp
Mounting	Stackable in a single cutout
Panel thickness	< 25 mm
Terminals	Hexagon studs, M4 screws and wire clamps E3 (DIN46282)

Electrical Data

Measured quantity	Active or Reactive Power
Response time	4 sec max.
Overload capacity	acc to IEC 51/DIN EN60051
Continuously	1.2 times rated voltage / current
Short duration	2 times for 5 sec : 1 overload 2 times for 0.5 sec : 9 overloads

Power consumption(Approx):-

Current path	< 0.2 VA
Voltage path types E1W, D1W,D1B,V1W,V1B	< 3.0 VA
E1B	< 3.5 VA
D2W,D2B	< 3.4 VA
V3W	< 3.9 VA
V3B	< 4.3 VA
Enclosures code	IP 52 case
(IEC 529)	IP 00 for terminal without backcover

Insulation class	Group A according to VDE 0110
Rated insulation voltage	660 V
Proof voltage testing	2 kV
Installation category	300 VCAT III (IEC 1010)
Insulation resistance	> 50 Mohm at 500V DC

Reference Conditions

Accuracy class	1.5 according to IEC 51/ DIN EN 60051
Reference conditions	
Ambient temperature	23 °C ± 2 °C
Position of use	Nominal position + 1°
Input	Full-scale power value Pw or Pb
Feasibility factor	"Lambda" = Pw/Ps or Pb / Ps
Power factor	$\cos \varphi = 1 + 0.01$ for Watt meters & $\sin \varphi = 1 + 0.01$ for Var meters
Voltage	Rated voltage + 2%
Frequency	45-65 Hz (50 Hz + 0.1% for E1B)
Current	20% to 120% of rated current
Others	IEC 51/ DIN EN 60051

Electrical and mechanical zero point in the meter are not necessarily identical. Zero adjustment should be done when only voltage is applied and current circuit not energised.

Nominal range of use	
Ambient temperature	0 ... 50°C
Position of use	Nominal position +5°
External magnetic field	At 0.4 kA/m
Voltage	Rated voltage + 15%
Power factor	$\cos \varphi = 1$ to 0.5 (ind.) for active power $\sin \varphi = 1$ to 0.5 (ind.) for reactive power Frequency 45-65 Hz (50 Hz + 1% for E1B)

Environmental Conditions

Climatic suitability	Climate category II as per IS:1248 (climatic class 3 according to VDE/VDI 3540)
Operating temperature	-10 ... + 55°C
Storage temperature	-25 ... + 65°C
Relative humidity	< 75% annual average, non-condensing
Shock resistance	15g, for pulse duration 11ms
Vibration resistance	10-55-10Hz for ampli. 0.15mm (1.5 g at 50Hz)

Function principle

For active and reactive power measurement, a moving-coil indicator is used to indicate watts and vars for which an analogue DC signal is obtained from a power converter attached to the case of the indicator.

Schematic Diagram.

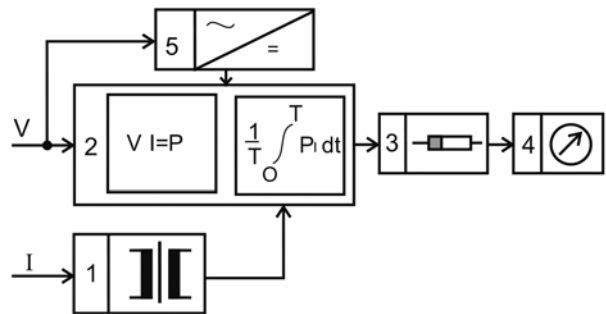

The power converter uses one, two or three multiplier systems 2 depending on the measurement of balanced or unbalanced load AC systems. Current transformers 1 provide the input current to the multiplier circuit.

The multipliers form the product of the instantaneous values of current and voltage (TDM principle). Subsequently, the product resultant is integrated, thereby suppressing the AC ripple. Subsequently product proportional output is delivered to 3. There the voltage is converted into Current, whose magnitude also depends on Feasibility Factor (λ). Finally this current is fed to the moving coil movement, 4. For the instrument DC power supply is obtained from input voltage, 5.

Dimensions

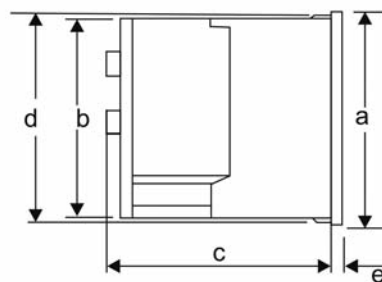

Dimensions	(in mm)	LML96	LML144
Bezel	a	96	144
Case	b	90	136
Depth	c	106	106
	d	131	131
	d	91.5	137.5
	e	5.5	5.5
Cutout Size		92 ^{+0.8}	138 ^{+0.1}
Weight (approx.)		0.73 to 0.98 kg.	0.9 to 1.2 kg.

Connection

Active power

E1W-Single phase
(One element)

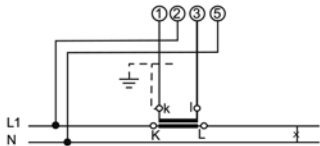

D1W -Three phase, three-wire
AC Supply with balanced load
(One element)

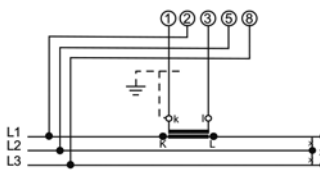

V1W -Three phase, four-wire
AC Supply with balanced load
(One element)

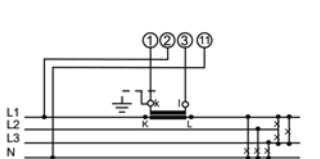

D2W -Three phase, three-wire
AC Supply with unbalanced load
(Two element)

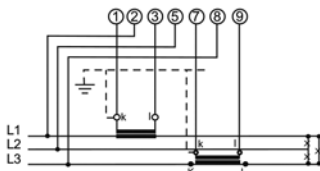

V3W -Three phase, four-wire
AC Supply with unbalanced load
(Three element)

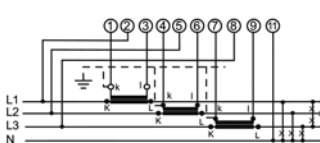

Reactive power

E1B-Single phase
(One element)

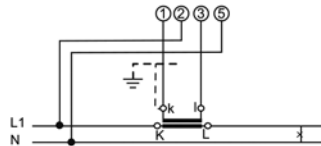

D1B -Three phase, three-wire
AC Supply with balanced load
(One element)

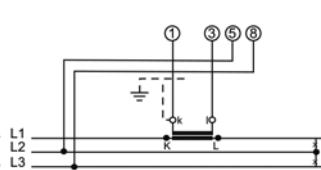

V1B -Three phase, four-wire
AC Supply with balanced load
(One element)

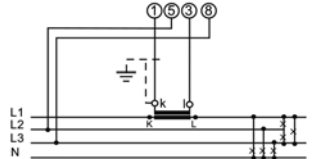

D2B -Three phase, three-wire
AC Supply with unbalanced load
(Two element)

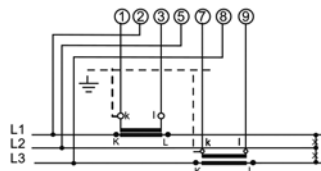

V3B -Three phase, four-wire AC
Supply with unbalanced load
(Three element)

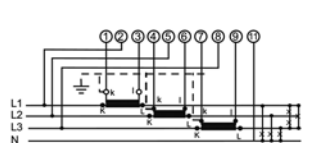

Safety Precautions

- 1) Instruments with damaged bezel or glasses must be disconnected from the mains.
- 2) Adequate safety clearance must be maintained to control panel fasteners and to sheet metal housing. If non - insulated connector wires are used.
- 3) The back cover must be snapped into place after connector wires have been clamped for protection against accidental contact.
- 4) Bezel, Scale and Glass may only be replaced under voltage free conditions.
- 5) Instruments to be used in grounded panel.

For more details and product codes, please contact our local office.

Contact



Sifam Tinsley Instrumentation Ltd

1 Warner Drive
Springwood Industrial Estate
Braintree, Essex
CM7 2YW

Tel: 01376 335271
E-mail: sales@sifamtinsley.com

www.sifamtinsley.co.uk